

RoHS Compliant

REV.	DESCRIPTION	SIGN	DATE
A	NEW	Fred.Tong	17/06/20
B	插拔力标准变更为8-25N	Fred.Tong	19/01/06
C	与客户统一标准改为少左脚	Fred.Tong	21/07/10

NOTES:

1.ELECTRONIC:

CONTACT CURRENT RATING:1.5A
 CONTACT RESISTANCE: 30mohm MAX
 INSULATION RESISTANCE: 1000 Mohm MIN
 WITHSTAND VOLTAGE:AC 500V,1min.

2.MECHANICAL:

MATING FORCE:25N MAX
 UNMATED FORCE:8-25N.

3.ENVIRONMENT CHARACTERISTICS:

OPERATING TEMPERATURE:-55°C TO +105°C

4.标示"▲"符号的尺寸为重点检验尺寸。

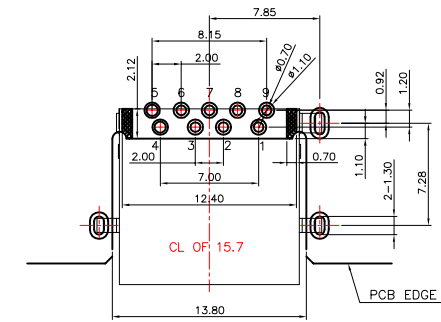
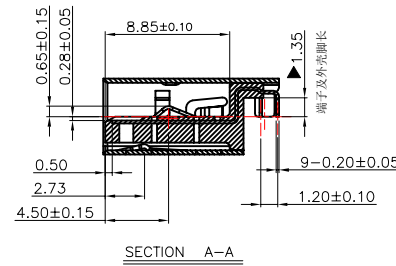
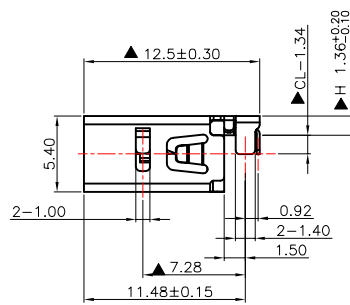
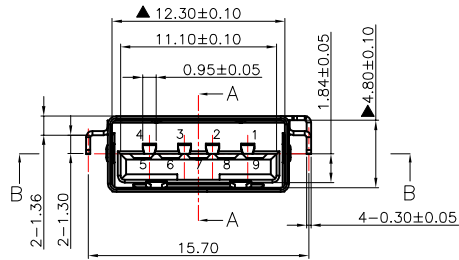
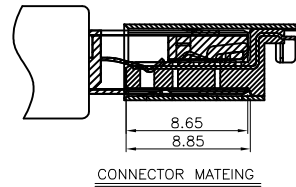
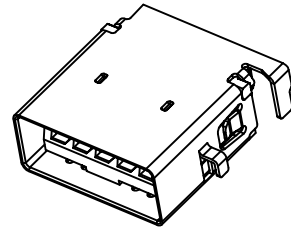
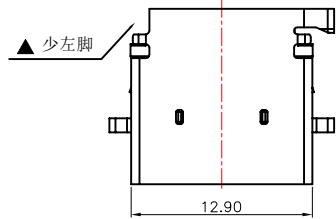

TOLERANCE: ±0.05, THICKNESS: 1.0~1.2mm
 RECOMMENDED PCB LAYOUT
 (TOP VIEW)
 KEEP OUT AREA

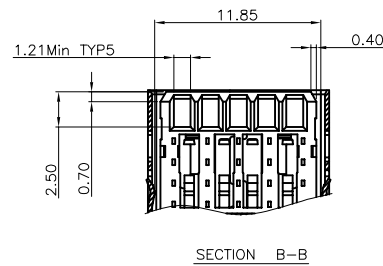
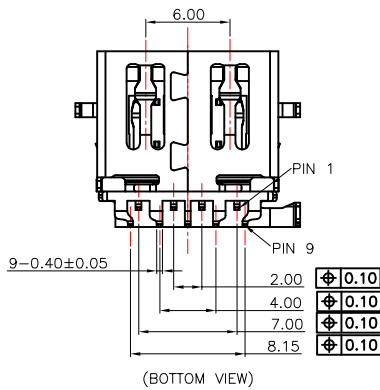

2.00	±0.10
4.00	±0.10
7.00	±0.10
8.15	±0.10

3	SHELL	1	SUS201 T=0.3mm	NI PLATED
2	CONTACT	9	COPPER ALLOY T=0.2mm	G/F AU/TIN PLATED
1	HOUSING	1	(PA9T)THERMOPLASTIC	(UL 94V-0) BLUE/BLACK
No.	PART NAME	QTY	MATERIAL	REMARK

GENERAL TOLERANCES (UNLESS SPECIFIED)		DRAWN BY	DATE
ITEM	MM	qinyu	2021/07/10
3 PLACE	±0.05	CHECKED BY	DATE
2 PLACE	±0.10	APPROVED BY	DATE
1 PLACE	±0.20		
0 PLACE	±0.30		
ANGULAR ± 2'		ANGLE OF PROJECTION	
METRIC	U.S.		
MM	INCHES		

EDOM ELECTRONICS TEL: +86 0755 27801940
 Mob: +86 15889397634
 www.techedom.com

TITLE:
 USB3.0 AF R&A DIP RVS 少左脚12.50

SIZE A4 PART NO. EU09FL1N12155

SCALE N/A SHEEL 1 OF 1

THIS DRAWING CONTAINS INFORMATION THAT IS PROPRIETARY TO EDOM INCORPORATED AND SHOULD NOT BE USE WITHOUT WRITTEN PERMISSION

REV. A

RoHS

38.4
32.4

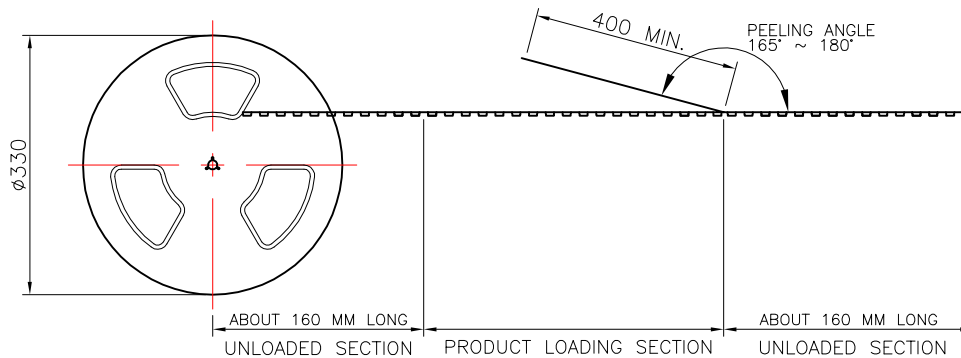

USER DIRECTION OF UNREELING →

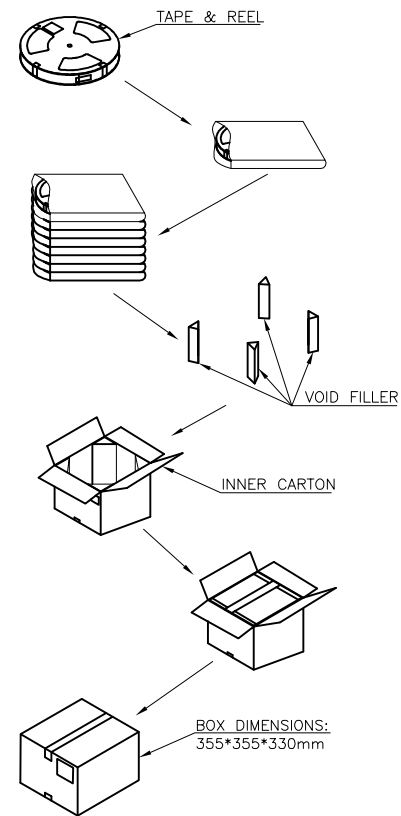
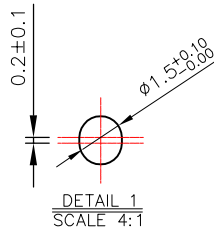
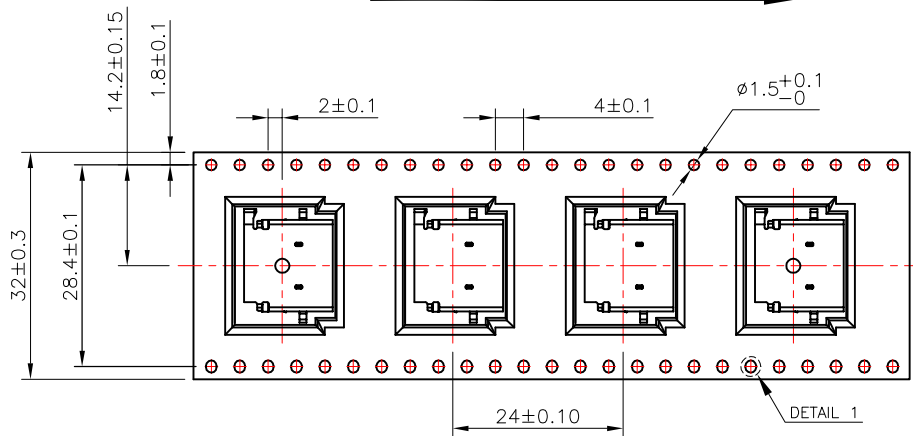

400	8	3200 PCS	-- KG	-- KG
PCS/	REELS/	QUANTITY	GROSS	NET
REEL	CARTON		WEIGHT	WEIGHT

NOTE:

- MATERIAL:
 BOX: FIBREBOARD, CORRUGATED, DOUBLE WALL
 TAPE: POLYSTYRENES, HEAT-RESISTANT TEMPERATURE: 120°C, BLACK COLOR.
 REEL: POLYSTYRENES, HEAT-RESISTANT TEMPERATURE: 70°C, BLUE COLOR.
 BAG: POLYETHYLENE, HEAT-RESISTANT TEMPERATURE: 100°C.
- PEELING STRENGTH: 0.1 ~ 1.3 N (10 ~ 130 GRAMS)
- PEELING SPEED: 300 mm/min.
- EACH BAG SHALL BE INCLUDED DESICCANT.

GENERAL TOLERANCES (UNLESS SPECIFIED)		DRAWN BY qinyu	DATE 2021/07/10	TEL: +86 0755 27801940 Mob: +86 15889397634 www.techedom.com
ITEM	MM	INCH	CHECKED BY /	
3 PLACE	±0.05	±0.005	APPROVED BY	TITLE: USB3.0 AF R&A DIP RVS 少左脚L12.50
2 PLACE	±0.10	±0.01	DATE	SIZE A4
1 PLACE	±0.20	±0.015	ANGLE OF PROJECTION	PART NO. EU09FL1N12155
0 PLACE	±0.30	±0.02	ANGULAR ± 2'	SCALE N/A
METRIC	MM	U.S.	INCHES	SHEET 1 OF 1
THIS DRAWING CONTAINS INFORMATION THAT IS PROPRIETARY TO EDOM INCORPORATED AND SHOULD NOT BE USE WITHOUT WRITTEN PERMISSION				REV. A