

RoHS Compliant

REV.	DESCRIPTION	SIGN	DATE
A	NEW	Fred.Tong	2018/12/27

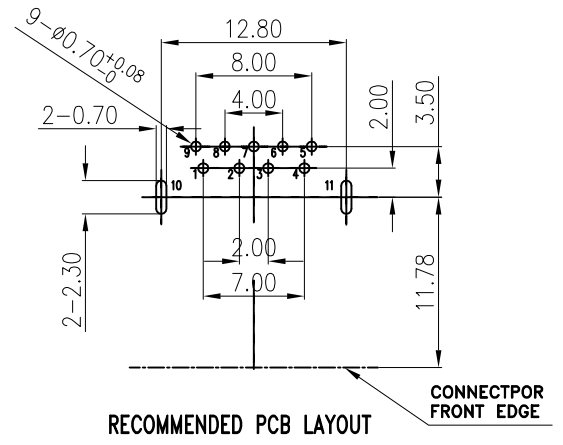
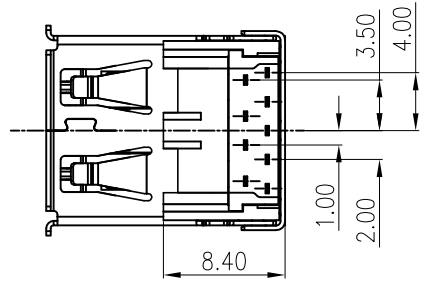
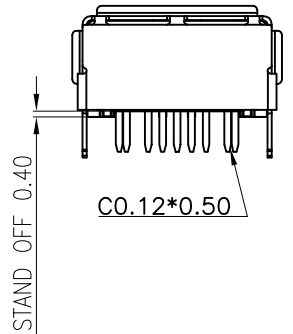
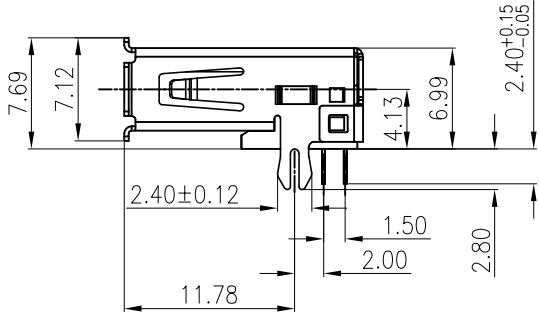
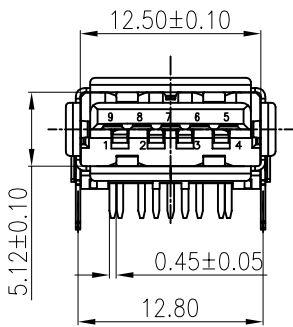
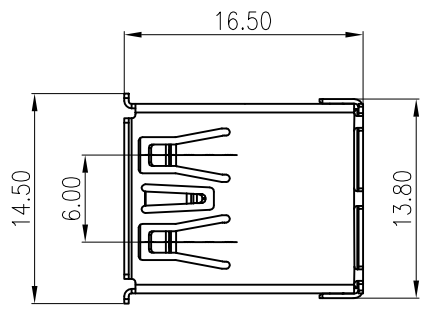

- NOTES:
- ELECTRONIC:
 - CONTACT RESISTANCE: 30mohm MAX
 - INSULATION RESISTANCE: 1000 Mohm MIN
 - WITHSTAND VOLTAGE: AC 500V, 1min.
 - MECHANICAL:
 - DURABILITY: 1500 CYCLE.
 - ENVIRONMENT CHARACTERISTICS:
 - OPERATING TEMPERATURE: -55°C TO +105°C
 - RECOMMENDER PCB THICKNESS 1.2 TO 1.6MM
 - CUSTOMER NO.: USB-3A-R01-1011

6. MATERIAL LIST:

No.	PART NAME	QTY	MATERIAL	REMARK
5	SHELL	1	SPCC	NI PLATED
4	5PIN	5	COPPER ALLOY	1U AU/TIN PLATED
3	4PIN	4	PHOSPHOR BRONZE	1U AU/TIN PLATED
2	COVER	1	PBT 蓝色	(UL 94V-0)
1	HOUSING	1	PBT 蓝色	(UL 94V-0)

GENERAL TOLERANCES (UNLESS SPECIFIED)			DRAWN BY Alen.Yu	DATE 2018/12/27	TEL: +86 0755 27801940 Mob: +86 15889397634 www.techedom.com
ITEM	MM	INCH	CHECKED BY Liang.Li	DATE 2018/12/27	
3 PLACE	±0.15	±0.005	APPROVED BY Fred.Tong	DATE 2018/12/27	TITLE: USB 3.0 A FEMALE 90度 DIP 铁壳鱼叉 镀镍
2 PLACE	±0.25	±0.01	ANGLE OF PROJECTION	SIZE A4	
1 PLACE	±0.35	±0.015	METRIC	U.S.	PART NO. EU09FL2N1274
0 PLACE	±0.50	±0.02	MM	INCHES	
					SCALE N/A
THIS DRAWING CONTAINS INFORMATION THAT IS PROPRIETARY TO EDOM INCORPORATED AND SHOULD NOT BE USE WITHOUT WRITTEN PERMISSION					SHEET 1 OF 1 REV. A