

RoHS Compliant

REV.	DESCRIPTION	SIGN	DATE
A	NEW	RuoBiaoLing	2018/11/28

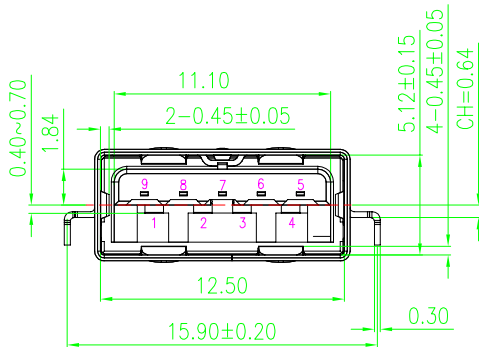

Pin NUMBER	SIGNAL NAME
1	VBUS
2	D-
3	D+
4	GND
5	StdA_SSRX-
6	StdA_SSRX+
7	GND_DRAIN
8	StdA_SSTX-
9	StdA_SSTX+
Shell	Shield

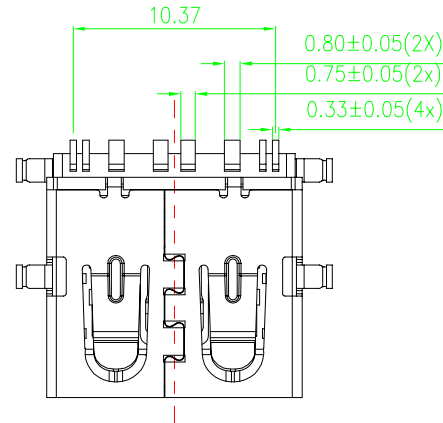
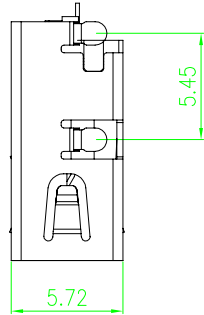
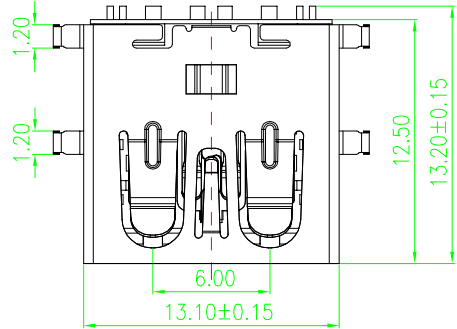
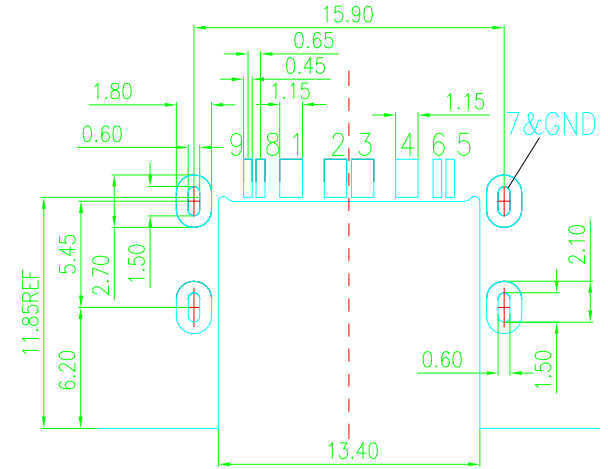

TOLERANCE: ±0.05, RECOMMENDED PCB LAYOUT (TOP VIEW)

NOTES:

- ELECTRONIC:
CONTACT CURRENT RATING:1.5A
CONTACT RESISTANCE: 30mohm MAX
INSULATION RESISTANCE: 1000 Mohm MIN
WITHSTAND VOLTAGE:AC 500V,1min.
- MECHANICAL:
MATING FORCE:35N MAX
UNMATED FORCE:8N MIN.
- ENVIRONMENT CHARACTERISTICS:
OPERTING TEMPERATURE:-25°C TO +85°C
- MATERIAL LIST:

No.	PART NAME	QTY	MATERIAL	REMARK
3	SHELL	1	STAINLESS TEEL	NI PLATED
2	CONTACT	9	COPPER ALLOY	AU /TIN PLATED
1	HOUSING	1	THERMOPLASTIC	(UL 94V-0) BLUE

GENERAL TOLERANCES (UNLESS SPECIFIED)			DRAWN BY RuoBiaoLing	DATE 2018/11/28
ITEM	MM	INCH	CHECKED BY /	DATE
3 PLACE	±0.15	±0.005		
2 PLACE	±0.25	±0.01		
1 PLACE	±0.35	±0.015	APPROVED BY Fred.Tong	DATE 2018/11/28
0 PLACE	±0.50	±0.02		
ANGULAR ± 3°			ANGLE OF PROJECTION	
METRIC		U.S.		
MM		+NGHES-		

EDOM ELECTRONICS TEL: +86 0755 27801940
Mob: +86 15889397634
www.techedom.com

TITLE:
USB AF 沉板H3.50 GEN2 10G

SIZE A4	PART NO. EU09F2L3N11367SR
SCALE N/A	SHEET 1 OF 1

THIS DRAWING CONTAINS INFORMATION THAT IS PROPRIETARY TO EDOM INCORPORATED AND SHOULD NOT BE USE WITHOUT WRITTEN PERMISSION

REV.
A