

RoHS Compliant

REV.	DESCRIPTION	SIGN	DATE
A	NEW	Fred.Tong	16/06/18

A
B
C
D

A
B
C
D

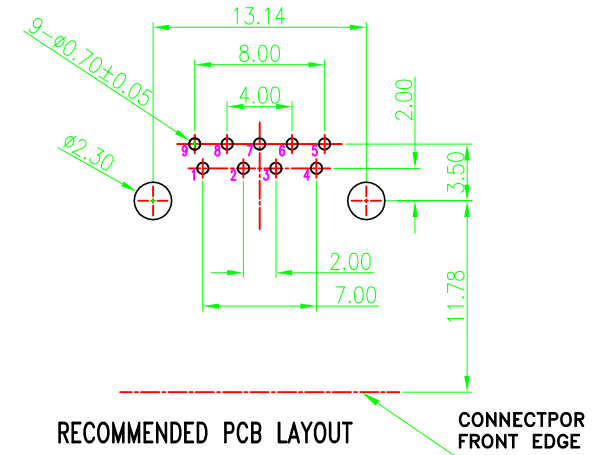
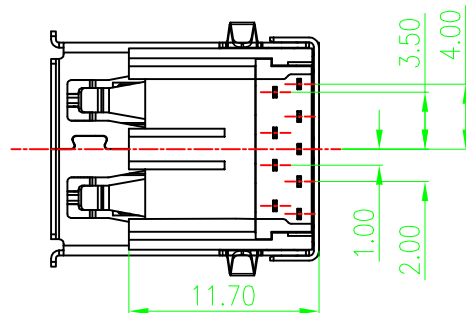
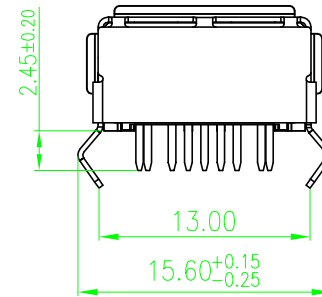
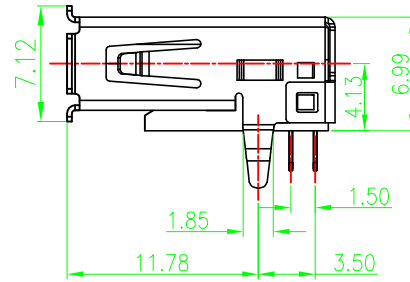
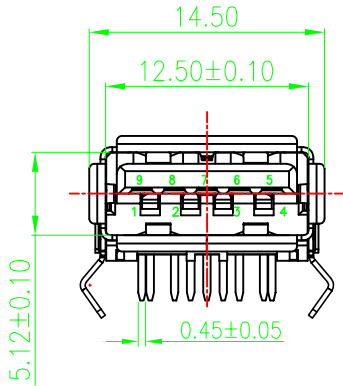
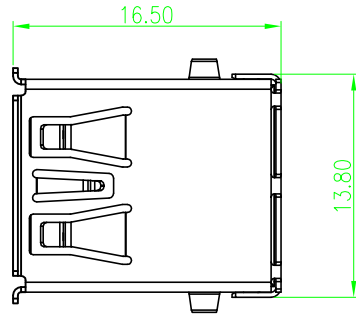

NOTES:

- ELECTRONIC:
CONTACT RESISTANCE: 30mohm MAX
INSULATION RESISTANCE: 1000 Mohm MIN
WITHSTAND VOLTAGE: AC 500V, 1min.
- MECHANICAL:
DURABILITY: 3000 CYCLE.
- ENVIRONMENT CHARACTERISTICS:
OPERATING TEMPERATURE: -55°C TO +105°C
- RECOMMENDER PCB THICKNESS 1.2 TO 1.60MM

5. MATERIAL LIST:

No.	PART NAME	QTY	MATERIAL	REMARK
5	SHELL	1	COPPER ALLOY	NI PLATED
4	5PIN	5	COPPER ALLOY	AU/TIN PLATED
3	4PIN	4	COPPER ALLOY	AU/TIN PLATED
2	COVER	1	LCP BLUE	(UL 94V-0)
1	HOUSING	1	LCP BLUE	(UL 94V-0)

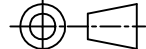
GENERAL TOLERANCES (UNLESS SPECIFIED)			DRAWN BY	DATE	 TEL: +86 0755 27801940 Mob: +86 15889397634 www.techedom.com		
ITEM	MM	INCH	Alen.Yu	16/06/18			
3 PLACE	±0.15	±0.005	CHECKED BY	DATE	TITLE: USB 3.0 A FEMALE 90度 DIP 弯脚 侧弹朝后 脚长 2.45		
2 PLACE	±0.25	±0.01	Liang.Li	16/06/18			
1 PLACE	±0.35	±0.015	APPROVED BY	DATE			
0 PLACE	±0.50	±0.02	Fred.Tong	16/06/18	ANGLE OF PROJECTION 	SIZE A4	PART NO. EU09F2L1N12306ST
ANGULAR ± 3°			SCALE N/A		SHEEL 1 OF 1		

THIS DRAWING CONTAINS INFORMATION THAT IS PROPRIETARY TO EDOM INCORPORATED AND SHOULD NOT BE USE WITHOUT WRITTEN PERMISSION

1

2

3

4

5

REV. A