

RoHS Compliant

| REV. | DESCRIPTION | SIGN      | DATE     |
|------|-------------|-----------|----------|
| A    | NEW         | Fred.Tong | 16/06/18 |

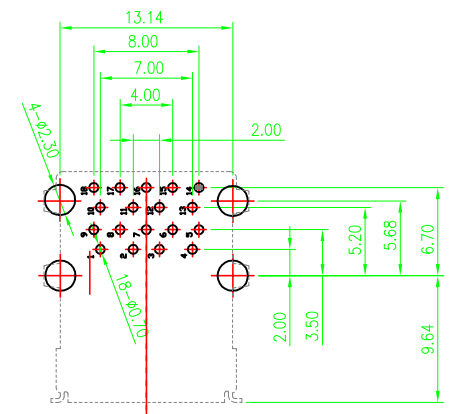

RECOMMENDED PCB LAYOUT

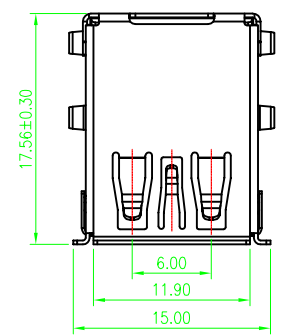
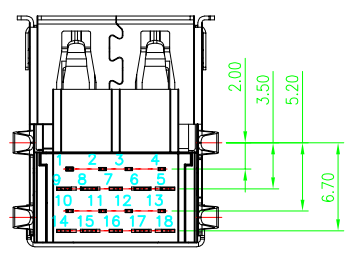
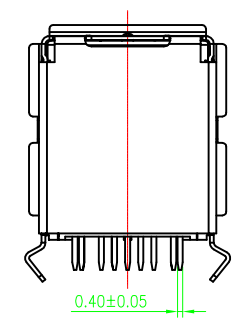
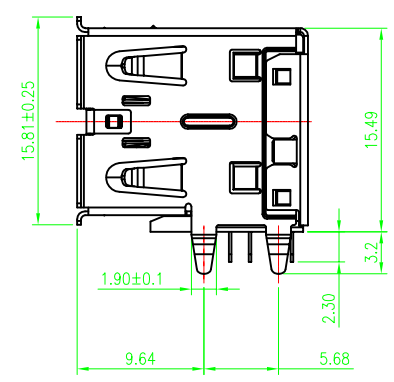
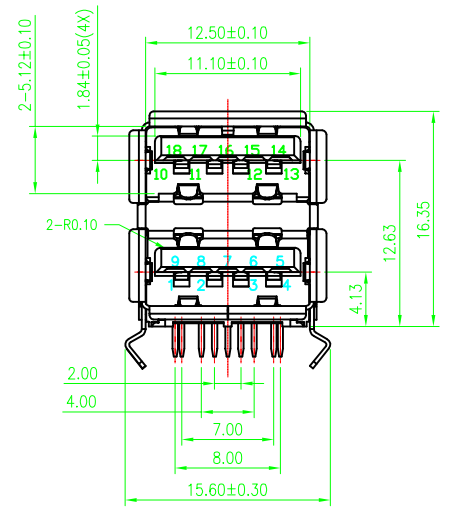

NOTES:

- 1.ELECTRONIC:  
CONTACT RESISTANCE: 30mohm MAX  
INSULATION RESISTANCE: 1000 Mohm MIN  
WITHSTAND VOLTAGE:AC 500V,1min.
- 2.MECHANICAL:  
DURABILITY: 1500 CYCLE.
- 3.ENVIRONMENT CHARACTERISTICS:  
OPERTING TEMPERATURE:-55°C TO +105°C
- 4.RECOMMANDER PCB THICKNESS 1.2 TO 1.60MM
- 5.MATERIAL LIST:

| No. | PART NAME | QTY | MATERIAL        | REMARK        |
|-----|-----------|-----|-----------------|---------------|
| 5   | SHELL     | 1   | STAINLESS STEEL | NI PLATED     |
| 4   | 5PIN      | 10  | COPPER ALLOY    | AU/TIN PLATED |
| 3   | 4PIN      | 8   | COPPER ALLOY    | AU/TIN PLATED |
| 2   | COVER     | 1   | LCP BLUE        | (UL 94V-0)    |
| 1   | HOUSING   | 1   | PA9T BLUE       | (UL 94V-0)    |

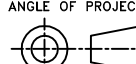
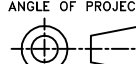
| GENERAL TOLERANCES (UNLESS SPECIFIED) |        |        | DRAWN BY  | DATE     |  TEL: +86 0755 27801940<br>Mob: +86 15889397634<br>www.techedom.com |
|---------------------------------------|--------|--------|---|----------|--|
| ITEM                                  | MM     | INCH   | Alen.Yu   | 16/06/18 |  |
| 3 PLACE                               | ±0.15  | ±0.005 | CHECKED BY  | DATE     |  |
| 2 PLACE                               | ±0.25  | ±0.01  | Liang.Li  | 16/06/18 |  |
| 1 PLACE                               | ±0.35  | ±0.015 | APPROVED BY   | DATE     | TITLE:<br><b>USB3.0 AF 双层 90度 DIP</b><br>蓝色高温料 不锈钢壳  |
| 0 PLACE                               | ±0.50  | ±0.02  | Fred.Tong   | 16/06/18 |  |
| ANGULAR ± 3°                          |        |        | ANGLE OF PROJECTION   |          | SIZE<br>A4   |
| METRIC                                | U.S.   |        |  |          |  |
| MM                                    | INCHES |        |  |          | SCALE<br>N/A   |

THIS DRAWING CONTAINS INFORMATION THAT IS PROPRIETARY TO EDOM INCORPORATED AND SHOULD NOT BE USE WITHOUT WRITTEN PERMISSION

REV. A