

RoHS Compliant

REV.	DESCRIPTION	SIGN	DATE
A	NEW	Fred.Tong	16/06/18

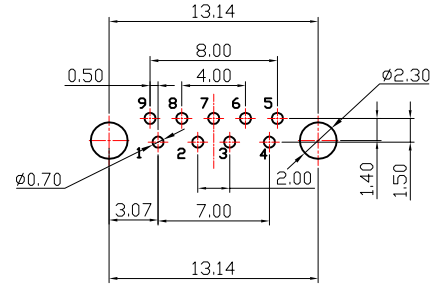
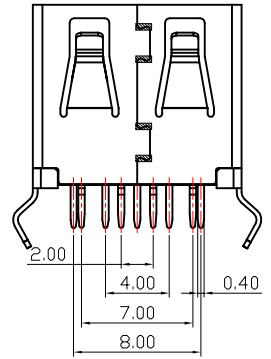
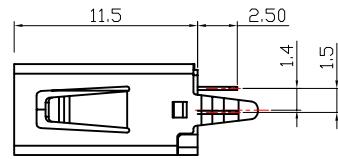
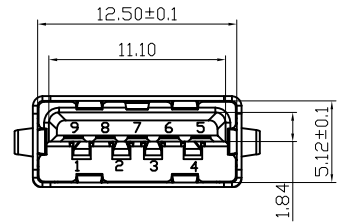
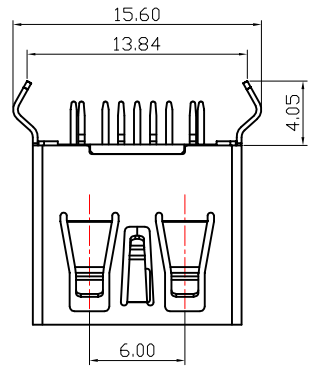

RECOMMENDED PCB LAYOUT

NOTES:



- ELECTRONIC:
CONTACT RESISTANCE: 30mohm MAX
INSULATION RESISTANCE: 1000 Mohm MIN
WITHSTAND VOLTAGE: AC 500V, 1min.
- MECHANICAL:
DURABILITY: 1500 CYCLE.
- ENVIRONMENT CHARACTERISTICS:
OPERATING TEMPERATURE: -55°C TO +105°C
- RECOMMENDER PCB THICKNESS 1.2 TO 1.6MM

5.料号说明: EU09F X X N12145

B=黑色 1=铜壳
L=蓝色 2=铁壳

6.MATERIAL LIST:

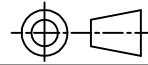
No.	PART NAME	QTY	MATERIAL	REMARK
4	SHELL	1	COPPER ALLOY	NI PLATED
3	5PIN	5	COPPER ALLOY	AU/TIN PLATED
2	4PIN	4	COPPER ALLOY	AU/TIN PLATED
1	HOUSING	1	LCP BLUE	(UL 94V-0)

GENERAL TOLERANCES (UNLESS SPECIFIED)			DRAWN BY	DATE	 TEL: +86 0755 27801940 Mob: +86 15889397634 www.techedom.com
ITEM	MM	INCH	Alen.Yu	16/06/18	
3 PLACE	±0.15	±0.005	CHECKED BY	DATE	TITLE: USB3.0 AF 180度 DIP H=11.50 弯脚 无卷边(插PIN式)
2 PLACE	±0.25	±0.01	Liang.Li	16/06/18	
1 PLACE	±0.35	±0.015	APPROVED BY	DATE	
0 PLACE	±0.50	±0.02	Fred.Tong	16/06/18	
ANGULAR ± 3°			ANGLE OF PROJECTION		SIZE A4
METRIC	U.S.				
MM	INCHES				SCALE N/A
THIS DRAWING CONTAINS INFORMATION THAT IS PROPRIETARY TO EDOM INCORPORATED AND SHOULD NOT BE USE WITHOUT WRITTEN PERMISSION					SHEET 1 OF 1

REV. A