

RHS Compliance

REV.	DESCRIPTION	SIGN	DATE
A	NEW	Fred.Tong	20/05/07

A

B

C

D

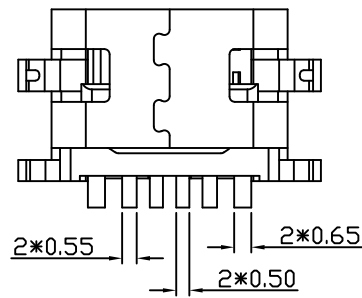
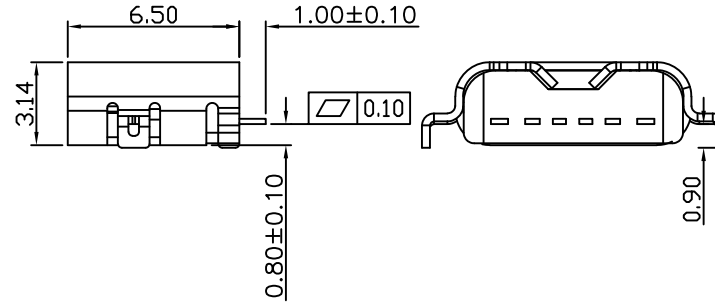
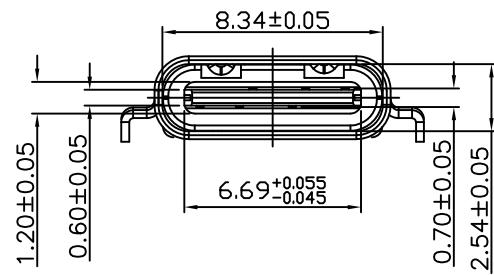
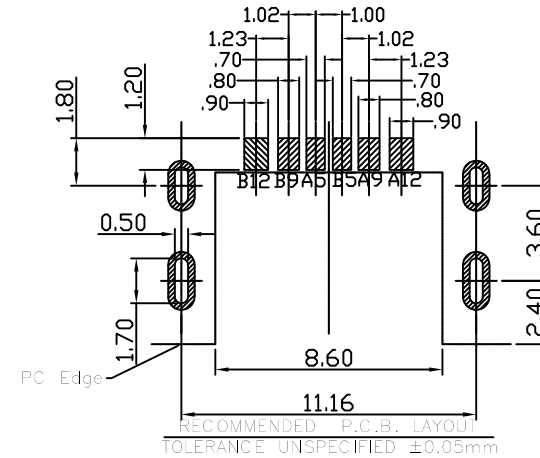
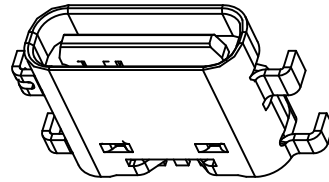
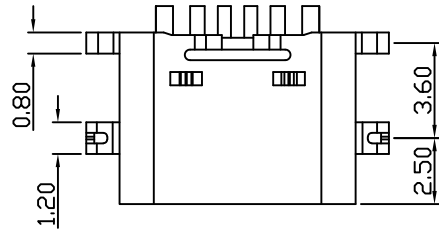

- ELECTRICAL: 3A FOR VBUS, 0.25A FOR OTHER PIN.
VOLTAGE: 5V AC MAX
WITHSTANDING VOLTAGE: 100V AC.
CONTACT RESISTANCE: 40mΩ MAX.
INSULATION RESISTANCE: 100MΩ MIN.
- MECHANICAL:
INSERTION: 5~20N.
EXTRACTION: 8~20N.
DURABILITY: 10000 CYCLES
- ENVIRONMENTAL
TEMPERATURE RANGE -55°C ~ +85°C

4.MATERIAL LIST:

No.	PART NAME	QTY	MATERIAL	REMARK
4	MID PLATE	1	STAINLESS STEEL	NI PLATED
3	SHELL	1	STAINLESS STEEL	NI PLATED
2	CONTACT	6	COPPER ALLOY	AU/TIN PLATED
1	HOUSING	1	THERMOPLASTIC(LCP)	(UL 94V-0)

GENERAL TOLERANCES (UNLESS SPECIFIED)			DRAWN BY	DATE
ITEM	MM	INCH	Alen.Yu	20/05/07
3 PLACE	±0.15	±0.005	CHECKED BY	DATE
2 PLACE	±0.25	±0.01	Liang.Li	20/05/07
1 PLACE	±0.35	±0.015	APPROVED BY	DATE
0 PLACE	±0.50	±0.02	Fred.Tong	20/05/07

EDOM ELECTRONICS
TEL: +86 0755 27801940
Mob: +86 15889397634
www.techedom.com

TITLE:
USB TYPE CF 6P 沉板0.80 SMT

ANGULAR ± 3°		ANGLE OF PROJECTION	SIZE	PART NO.
METRIC	U.S.		A4	EU06FB3N11319
MM	INCHES		SCALE	N/A

SCALE	SHEET	OF
N/A	1	1

THIS DRAWING CONTAINS INFORMATION THAT IS PROPRIETARY TO EDOM INCORPORATED AND SHOULD NOT BE USE WITHOUT WRITTEN PERMISSION

REV. B

1

2

3

4

5