

RoHS Compliant

REV.	DESCRIPTION	SIGN	DATE
A	NEW	Fred.Tong	17/06/20

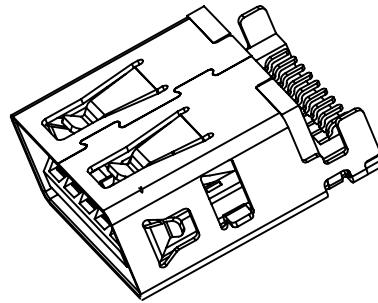
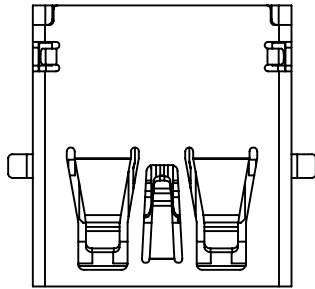

NOTES:

1.ELECTRONIC:

CONTACT CURRENT RATING: 1.5A  
 CONTACT RESISTANCE: 30mohm MAX  
 INSULATION RESISTANCE: 1000 Mohm MIN  
 WITHSTAND VOLTAGE: AC 500V,1min.

2.MECHANICAL:

MATING FORCE: 3.57KG MAX  
 UNMATED FORCE: 1.02KG MIN

3.ENVIRONMENT CHARACTERISTICS:

OPERTING TEMPERATURE: -55°C TO +105°C

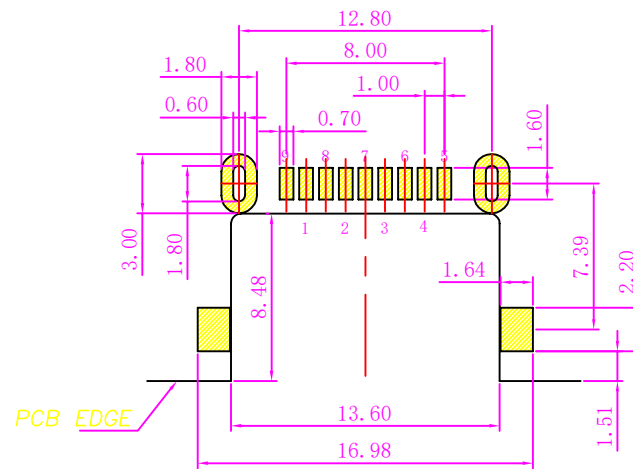
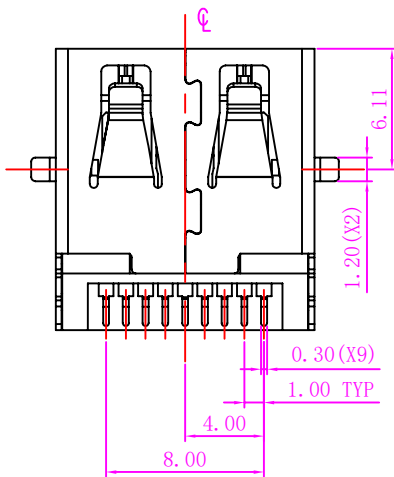
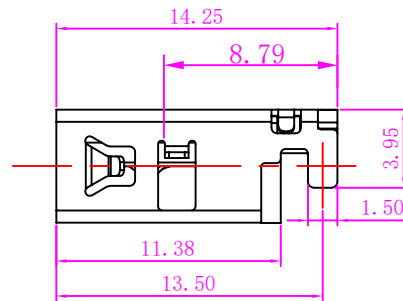
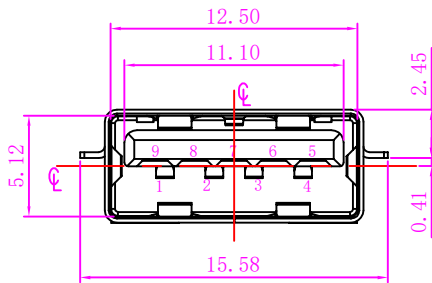

RECOMMENDED PCBA LAYOUT  
 (TOLERANCE+± 0.05)

MATERIAL LIST:

3	SHELL	1	COPPER ALLOY	NI PLATED
2	CONTACT	9	COPPER ALLOY	AU /TIN PLATED
1	HOUSING	1	THERMOPLASTIC(PA9T)	(UL 94V-0) BLACK/BLUE
No.	PART NAME	QTY	MATERIAL	REMARK

GENERAL TOLERANCES (UNLESS SPECIFIED)			DRAWN BY Alen.Yu		DATE 17/06/20		 TEL: +86 0755 27801940 Mob: +86 15889397634 www.techedom.com	
ITEM	MM	INCH	CHECKED BY	DATE	TITLE: USB 3.0 AF SMT H2.45			
3 PLACE	±0.15	±0.005	Liang.Li	17/06/20				
2 PLACE	±0.25	±0.01	APPROVED BY		PART NO. EU09FL1N12185			
1 PLACE	±0.35	±0.015	Fred.Tong					
0 PLACE	±0.50	±0.02	DATE 17/06/20		SCALE		SHEET 1 OF 1	
ANGULAR ± 3°			ANGLE OF PROJECTION		SIZE A4		REMARK	
METRIC			U.S.		SCALE		SHEET 1 OF 1	
MM			INCHES		SCALE		SHEET 1 OF 1	
THIS DRAWING CONTAINS INFORMATION THAT IS PROPRIETARY TO EDOM INCORPORATED AND SHOULD NOT BE USE WITHOUT WRITTEN PERMISSION								REV. A