

REV	ECN NO	DESCRIPTION	DATE	APPROVED
A	-	NEW RELEASED	2020.07.28	MAY.YU

Customer drawing

**RoHS**

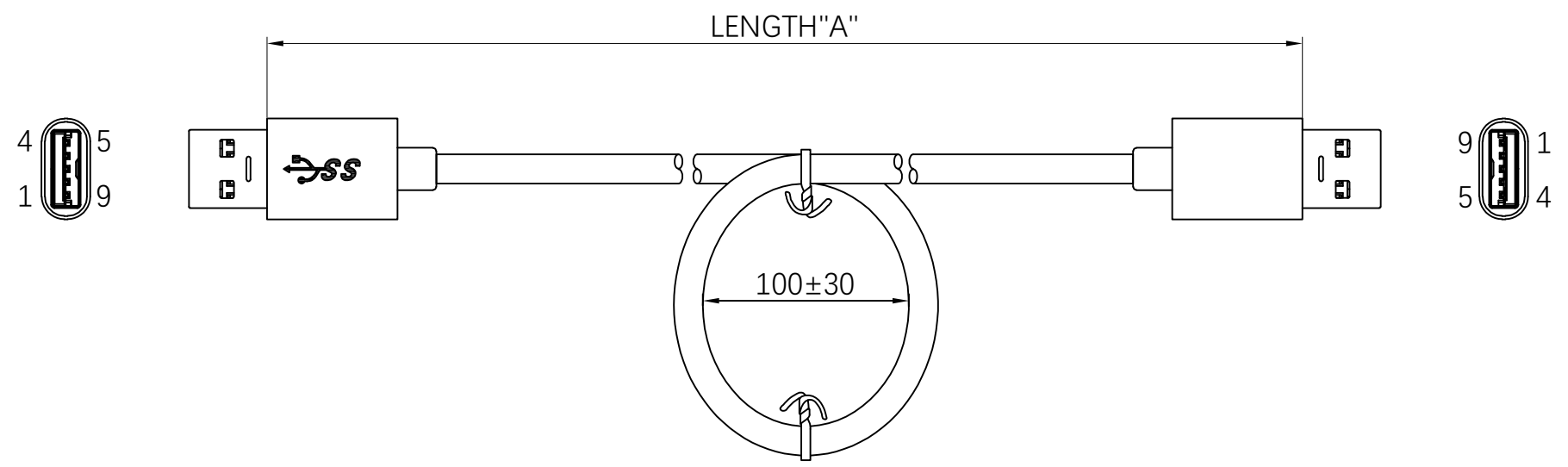

Electrical specifications:  
 Use of voltage range: 5V  
 Current range: 2A  
 Temperature range: -20°C~+80°C

Material specifications  
 Cable: USB3.0 Cable  
 Connector: USB3.0 Connector  
 Overmolding: Black PVC

Mechanical properties  
 Minimum bending radius: Fixed installation: 8x Cable OD  
 Flexible installation: 10x Cable OD

Electrical testing of finished cable  
 100% Open / Short / Miswiring testing  
 Insulation resistance: DC300V 10MΩ  
 Conductor resistance: 5Ω



UNMARKED TOLERANCES		TITLE		EDOM ELECTRONICS			
DIMENSIONS	TOLERANCE	STANDARD USB 3.0 CABLE ASSEMBLY		TEL: +86 0755 27801940		Mob: +86 15889397634	
x.	±0.5	CUSTOMER	-	CUSTOMER PART NO.	-		
x.x	±0.25	DRAWN BY	MAY.YU	PART NUMBER	usb3.0cable		
x.xx	±0.15	CHECKED BY	BILL.LEE	DRAWING NUMBER	usb3.0cable	A4	A
0 to 500	+15 / -0	APPROVED BY	TIGER.WANG	SCALE FREE	ALL DIMENSION UNIT IN MM		SHEET 1 OF 1
> 501	+3%/-0 <sub>of length</sub>						
ANGLES							
x°	±1°						

